

Serie C85

Dimensiones

Modelo culata tipo E

Amortiguación elástica: C□85E Diámetro - Carrera -

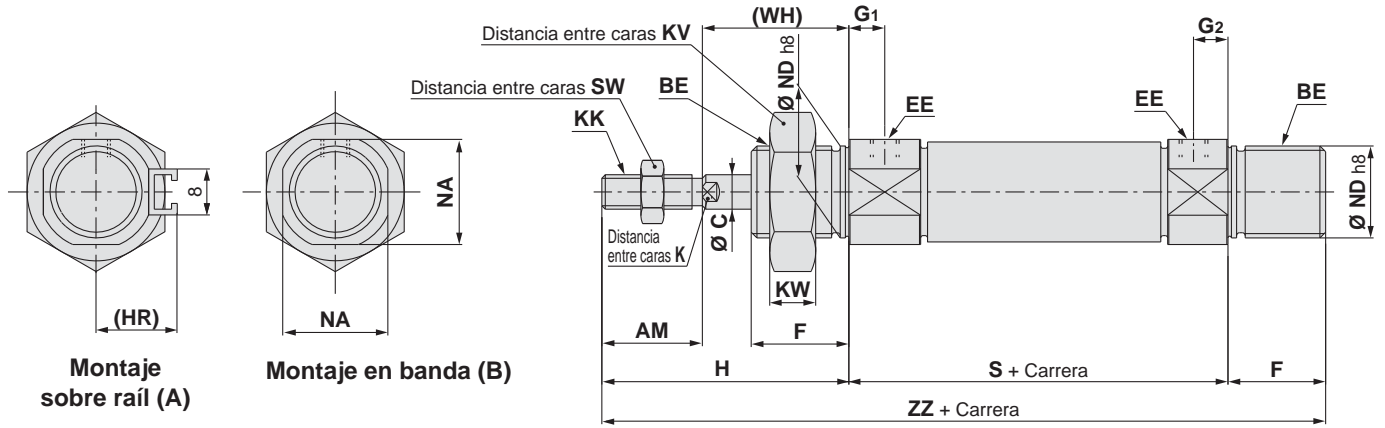

Con fuelle

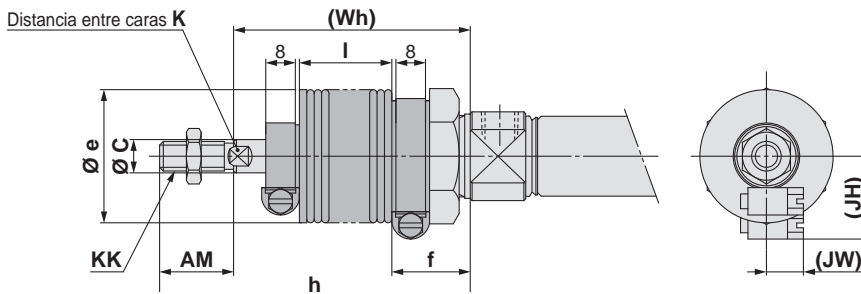

Dimensiones

Diámetro	AM	BE	C	EE	F	G ₁	G ₂	H	(HR)	K	KK	KV	KW	NA	ND	S	SW	(WH)	ZZ
8	12	M12 x 1.25	4	M5 x 0.8	12	7	5	28	13.4	—	M4 x 0.7	19	6	15	12	46	7	16	86
10	12	M12 x 1.25	4	M5 x 0.8	12	7	5	28	14.2	—	M4 x 0.7	19	6	15	12	46	7	16	86
12	16	M16 x 1.5	6	M5 x 0.8	17	8	6	38	14.2	5	M6 x 1	24	8	18.3	16	50	10	22	105
16	16	M16 x 1.5	6	M5 x 0.8	17	8	6	38	14.2	5	M6 x 1	24	8	18.3	16	56	10	22	111
20	20	M22 x 1.5	8	G1/8	20	8	8	44	17	6	M8 x 1.25	32	11	24	22	62	13	24	126
25	22	M22 x 1.5	10	G1/8	22	8	8	50	20	8	M10 x 1.25	32	11	30	22	65	17	28	137

Con fuelle

Diámetro	Carrera	AM	C	e	f	K	KK	h						
								1 a 50	51 a 100	101 a 150	151 a 200	201 a 300	301 a 400	401 a 500
20		20	8	36	22	6	M8 x 1.25	71	84	96	109	134	159	—
25		22	10	36	22	8	M10 x 1.25	74	87	99	112	137	162	187

Diámetro	Carrera	l							(JH) Referencia	(JW) Referencia	(Wh)						
		1 a 50	51 a 100	101 a 150	151 a 200	201 a 300	301 a 400	401 a 500			1 a 50	51 a 100	101 a 150	151 a 200	201 a 300	301 a 400	401 a 500
20		12.5	25	37.5	50	75	100	—	23.5	10.5	51	64	76	89	114	139	—
25		12.5	25	37.5	50	75	100	125	23.5	10.5	52	65	77	90	115	140	165

Consulte la página 12 del Modelo estándar con vástago simple para más información sobre los accesorios (rótula, horquilla hembra, articulación flotante).